

REV	MODIFICATIONS	DRAWN BY	CHECKED BY	DATE
A	CREATION	HE	HE	7/13/2011

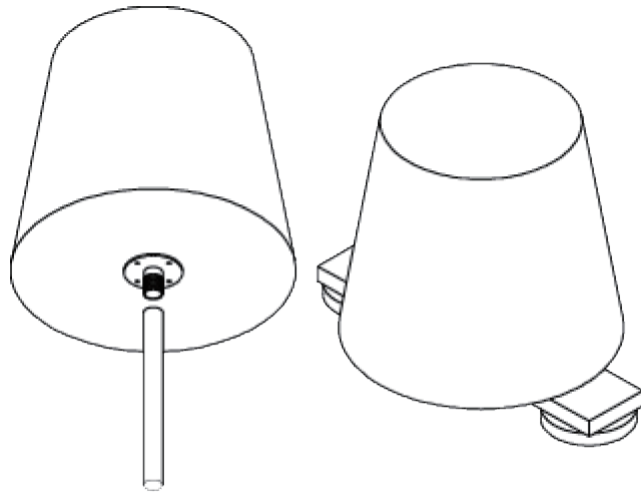

Colour	Standard is Bronze Olive. Option other colours to order.
Frequency Range	225-400 MHz
Polarisation	Vertical linear
Gain	+2dBi minimum over frequency range
VSWR	<1.9:1 over frequency range
Impedance (output)	50Ω (nominal)
Power Capability	100w CW
Connection	short coaxial cable tail with N type connector
Overall Dimensions (approx)	335mm (13.2 in) (h) x 375mm (14.8 in) (dia)
Mounting Pole Length	300mm (11.8 in) long, 25.4mm (1 in) dia; mounting clamps not included
Vehicle Magnetic Mount	500 x 80mm bar with magnetic couplings each end
Wind Survival	160 km/h (100mph)
Weight (approx)	7kg (15.4 lbs) (vehicle mount version)
Packed Weight	8kg (17.6 lbs) (vehicle mount version)



UNLESS OTHERWISE SPECIFIED DIMENSIONS : mm ANGLES : d.			
CUSTOMER N°	FILE N°	TITLE : <b>Broadband Omnidirectional UHF Ground to Air System</b>	
		SIZE A4	REV A Prod.   Doc.
SCALE : N.D.		<b>NMO-01-0040</b>	
		SHEET 1 of 1	

This drawing is the property of \_\_\_\_\_, and is issued on the condition that it is not copied or disclosed to any third party without prior written consent from \_\_\_\_\_